



RoHS

Specification

Client Name: _____

Client P/N: _____

Factory P/N: HL-PC-3216S11GC

Sending Date: _____

Client approval			Hong li approval		
Approval	Audit	Confirmation	Approval	Audit	Confirmation
			殷小平		谭娅
<input type="checkbox"/> Qualified <input type="checkbox"/> Unqualified			DATE: _____		

Adr: West side of Dongfeng Highway, Auto City, Huadu
District, Guangzhou, China

Tel: 020-86733333 (Switchboard)

Fax: 020-86733883 86733938 86733265

Web: www.honglitronic.com

HL-PC-3216S11GC

Features

- Extremely wide viewing angle
- Suitable for all SMT assembly and solder process
- Available on tape and reel
- Moisture sensitivity level: Level 4
- Package: 3000pcs/reel
- RoHS compliant



Description

The Greenish Yellow source color devices are made with AlGaInP on Substrate Light Emitting Diode

Applications

- Optical indicator
- Indoor display
- Backlighting in dashboard and switch
- Flat backlighting for LCD, symbol and display
- General use



ATTENTION
OBSERVE PRECAUTIONS
FOR HANDLING
ELECTROSTATIC
DISCHARGE
SENSITIVE
DEVICES

Package Dimensions

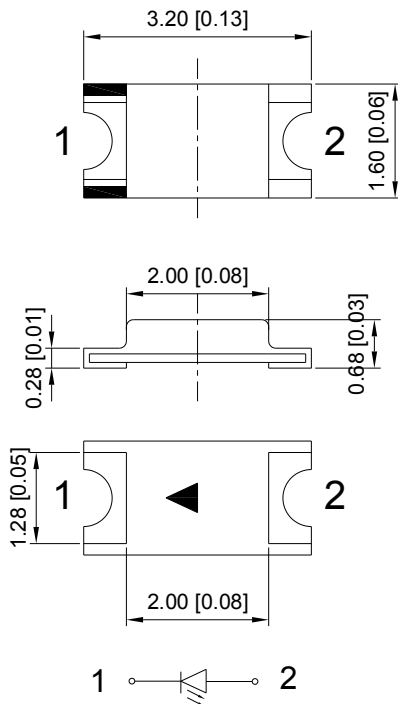

Recommended Soldering Pattern

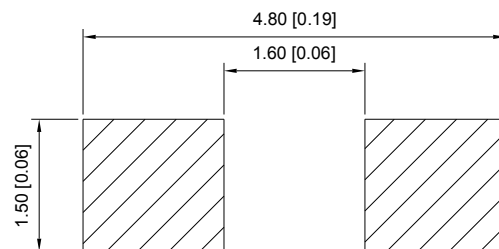

Notes:

1. All dimension units are millimeters.
2. All dimension tolerance is ± 0.15 mm unless otherwise noted.



HL-PC-3216S11GC

Selection Guide

Part No.	Dice	Lens Type	Luminous intensity(mcd) @ 20mA		Viewing Angle
			Min.	Max.	2θ1/2
HL-PC-3216S11GC	Greenish Yellow (AlGaInP)	Water Clear	70	90	120°
			90	120	
			120	160	

Note:

1. θ1/2 is the angle from optical centerline where the luminous intensity is 1/2 the optical centerline value.
2. the above luminous intensity measurement allowance tolerance ±10%.

Electrical / Optical Characteristics at Ta=25°C

Parameter	Symbol	Min.	Typ.	Max	Units	Test Conditions
Forward Voltage	V _F	1.8	--	2.4	V	I _F =20mA
Reverse Current	I _R	--	--	10	uA	V _R = 5V
Dominate Wavelength	λ _d	568	--	578	nm	I _F =20mA

Absolute Maximum Ratings at Ta=25°C

Parameter	Symbol	Value	Units
Power dissipation	P _d	75	mW
DC Forward Current	I _F	30	mA
Peak Forward Current [1]	I _{FP}	140	mA
Reverse Voltage	V _R	5	V
Electrostatic Discharge (HBM)	ESD	1000	V
Operating Temperature	T _{opr}	-40 ~ +85	°C
Storage Temperature	T _{stg}	-40 ~ +100	°C

Note:

1. 1/10 Duty cycle, 0.1ms pulse width.
2. The above forward voltage measurement allowance tolerance ±0.1V.

HL-PC-3216S11GC

Typical optical characteristics curves

Ambient Temperature VS. Forward Current

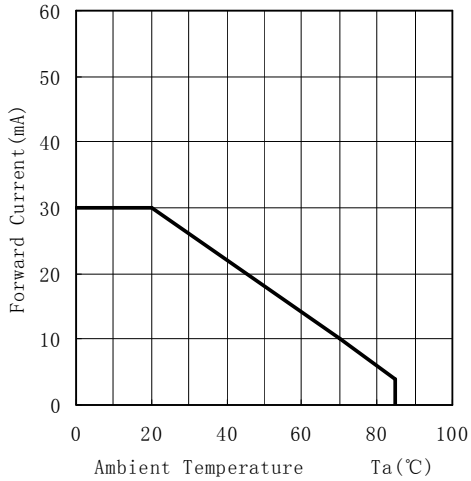

Forward Current VS. Relative Intensity

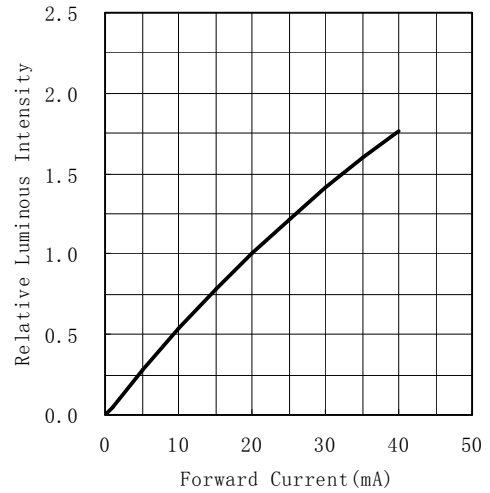

Forward Voltage VS. Forward Current

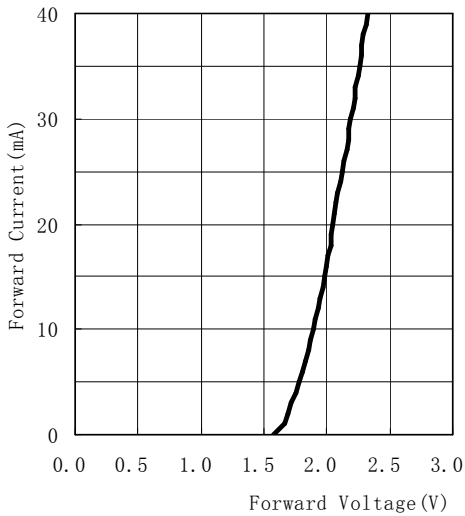

Ambient Temperature VS. Relative Intensity

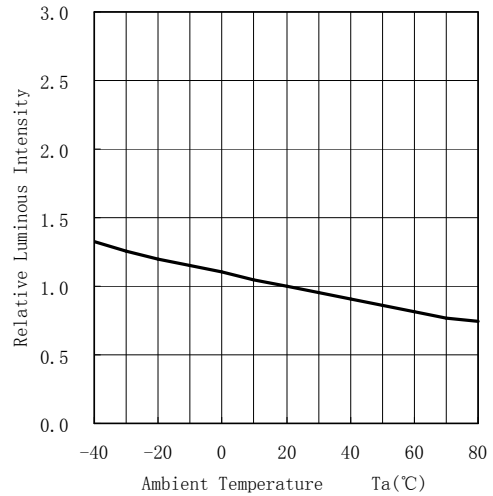

Relative spectral emission

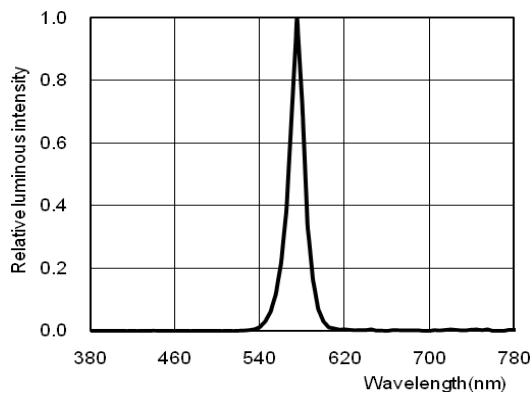
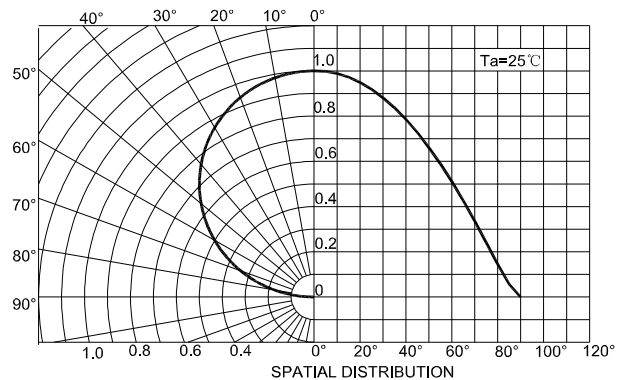

Diagram characteristics of radiation





HL-PC-3216S11GC

Reliability Test Items And Conditions

The reliability of products shall be satisfied with items listed below.
Confidence level :90%
LTPD :10%

No.	Items	Ref. Standard	Test Condition	Test Hours/ Cycles	Sample Size	Ac/Re
1	Reflow	JESD22-B106	Temp:260°Cmax T=10 sec	3 times.	22Pcs.	0/1
2	Temperature Cycle	JESD22-A104	100°C±5°C 30 min. ↑↓5 min -40°C±5°C 30 min.	100 Cycles	22Pcs.	0/1
3	Thermal Shock	JESD22-A106	100°C±5°C 5 min. ↑↓ -40°C±5°C 5 min.	100 Cycles	22Pcs.	0/1
4	High Temperature Storage	JESD22-A103	Temp:100°C±5°C	1000Hrs.	22Pcs.	0/1
5	Low Temperature Storage	JESD22-A119	Temp:-40°C±5°C	1000Hrs.	22Pcs.	0/1
6	DC Operating Life	JESD22-A108	Ta=25°C±5°C IF=20mA	1000Hrs.	22Pcs.	0/1
7	High Temperature High Humidity	JESD22-A101	85°C±5°C/ 85%RH IF=5mA	1000Hrs.	22Pcs.	0/1

*The technical information shown in the data sheets are limited to the typical characteristics and circuit examples of the referenced products. It does not constitute the warranting of industrial property nor the granting of any license.

HL-PC-3216S11GC

SMT Reflow Soldering Instructions

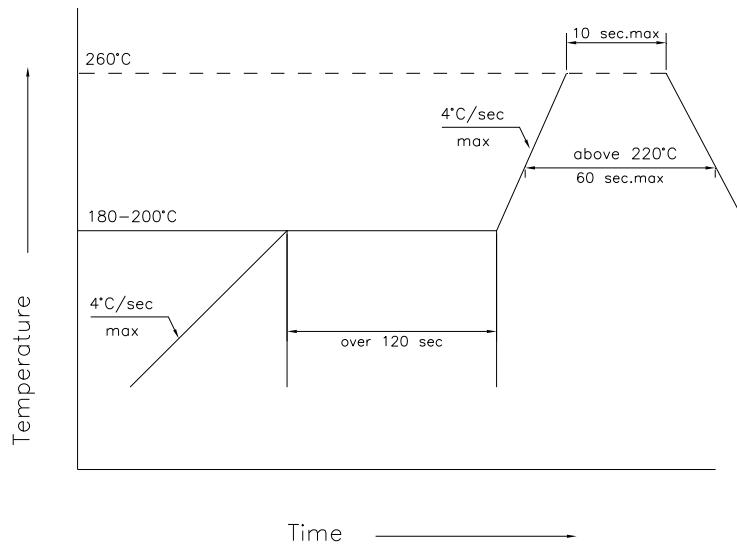

1. Reflow soldering should not be done more than two times
2. When soldering, do not put stress on the LEDs during heating

Soldering iron

1. When hand soldering, the temperature of the iron must be less than 300°C for 3 seconds
2. The hand solder should be done only one time

Repairing

Repair should not be done after the LEDs have been soldered. When repairing is unavoidable, a double-head soldering iron should be used (as below figure). It should be confirmed beforehand whether the characteristics of LEDs will or will not be damaged by repairing.

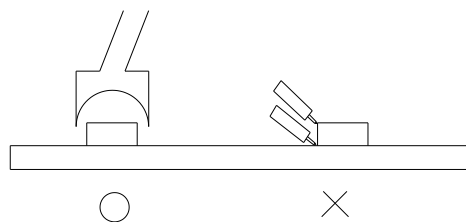

HL-PC-3216S11GC

Label

IV: Luminous intensity rank
 λ D: Dominate Wavelength
 VF: Forward voltage rank



HONGLITRONIC
鸿利光电

RoHS

Part No: XXXXXXXXXXXXXXXXXXXXXXXX
 IV: VF: WD:
 Quantity:
 Sealing date: XXXXXXXXXXXXXXXXXXXX



Tape Specifications (Units : mm)

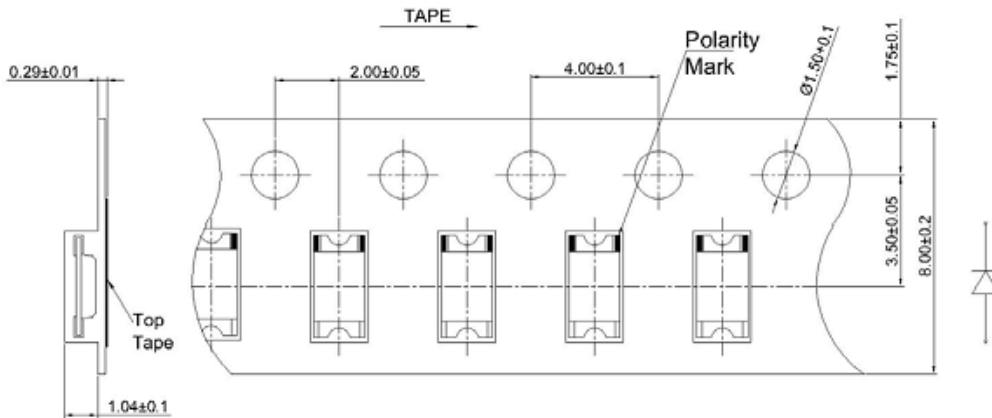

Reel Dimensions

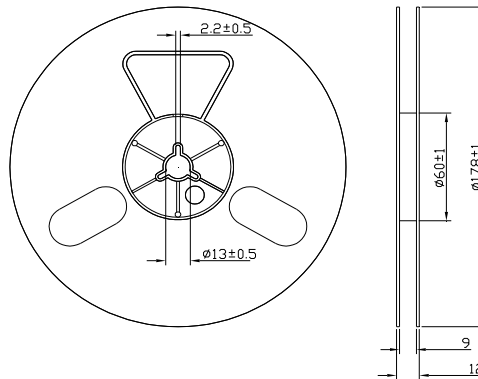

Moisture Resistant Packaging

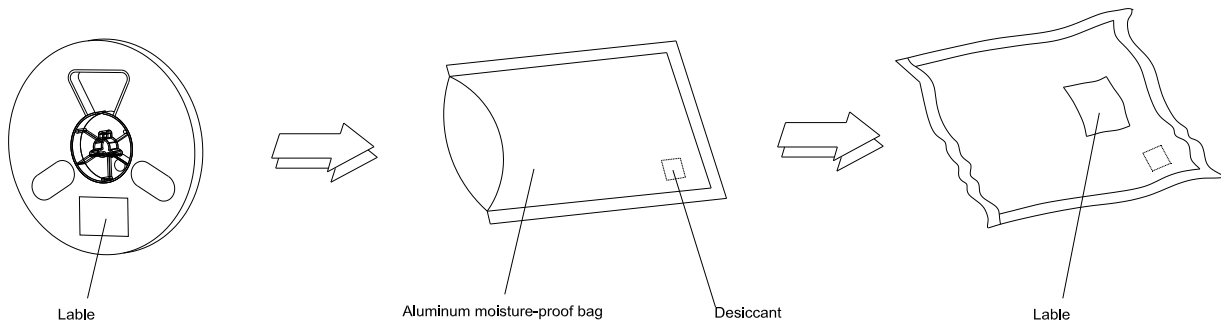

Note: The tolerances unless mentioned is ± 0.1 mm , Unit: mm