

# DEMEDUKIT

WWW.DEMSAY.COM

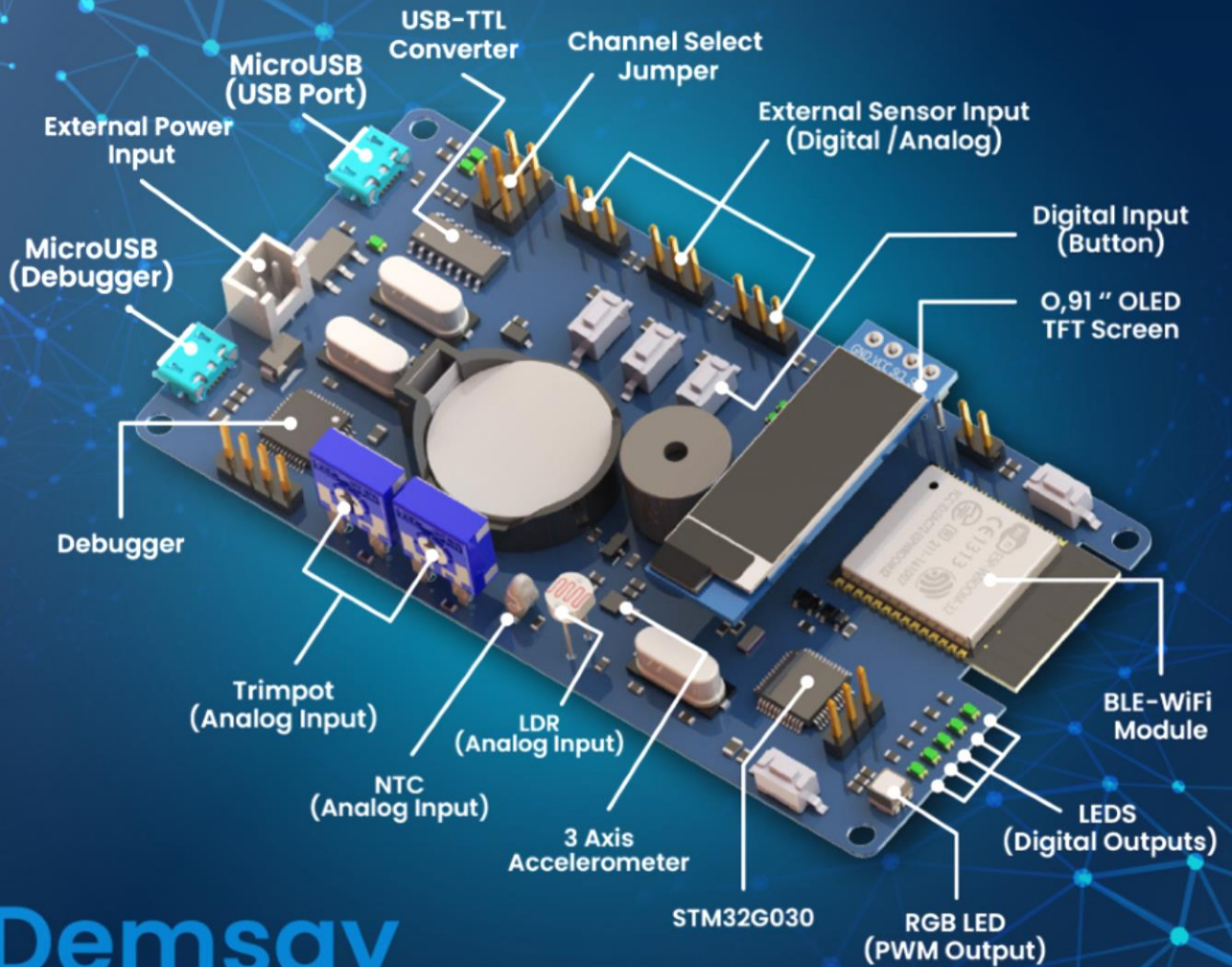

## Demsay Education Kit

REV 01

02.01.23

# Content

Introduction.....	1
1. Features.....	2
2. Hardware Layout.....	3
2.1. Top Layout.....	3
2.2. Bottom Layout .....	4
3. Schematic Diagram.....	5
3.1. Power Diagram.....	5
3.2. STLink/V2 Debugger and Programmer .....	5
3.3. STM32G030 MCU Connection .....	6
3.4. ESP32 – WROOM Connection .....	7
3.4.1. Programming Connection .....	7
3.4.2. ESP32 Connection .....	8
3.5. Input Connections.....	8
3.5.1. NTC ,Trim pots and LDR .....	8
3.5.2. External Sensor Input .....	9
3.6. I2C Interface .....	9
3.6.1. External I2C Port.....	9
3.6.2. 3 Axis Accelerometer .....	10
3.7. LED and RGB.....	10

# DEMSAY EDUCATION KIT USER GUIDE

## Introduction

DEMEDUKIT is a resource that will help you step into the exciting world of embedded systems. Embedded systems are systems that use microcontrollers and microcontrollers, which form the basis of almost every technological device today. This card and this documentation are designed for those who want to learn, apply and experience the basics of embedded systems.



This development board includes ESP32 and STM32G030 microcontrollers. ESP32 stands out with its dual-core processor, WiFi and Bluetooth support, digital inputs/outputs, internal antennas and luxurious analog features. STM32G030 stands out with its ARM Cortex-M0+ core, low power consumption, wide connection options, high-speed I/O pins and flexible memory structure. These two microcontrollers form the basis of the board and offer wide potential for different application areas.



Figure 1 Demsay Education Kit

## 1. Features

The Demsay Education Kit offers the following features:

- STM32G030 microcontroller in 48-LQFP package
- ESP32 microcontoller
- Eleven LEDs:
  - 5 digital output LEDs (LD2 ,LD3 ,LD4 ,LD5, LD6)
  - 1 RGB LED (RGB1)
  - 1 Power LED (LD1)
  - 2 Micro USB LEDs (RX1 ,TX1)
  - 2 digital output LEDs (ELD1 ,ELD2)
- Five buttons:
  - 3 digital input buttons
  - 1 STM Reset Button
  - 1 ESP Reset Buton
- Board power supply:
  - Micro USB( 5V )
  - External Power Input ( 3.3V)
- On-board ST-LINK/V2 debugger and programmer with SWD connector
- 2 Trimpots ( Analog Input)
- 3 External Sensor Input ( Digital / Analog)
- 1 NTC ( Analog Input)
- 1 LDR ( Analog Input)
- 1 piece 3 Axis Accelerometer
- External I2C connection
- 1 Buzzer
- 1 Battery to RTC application

## 2. Hardware Layout

### 2.1. Top Layout

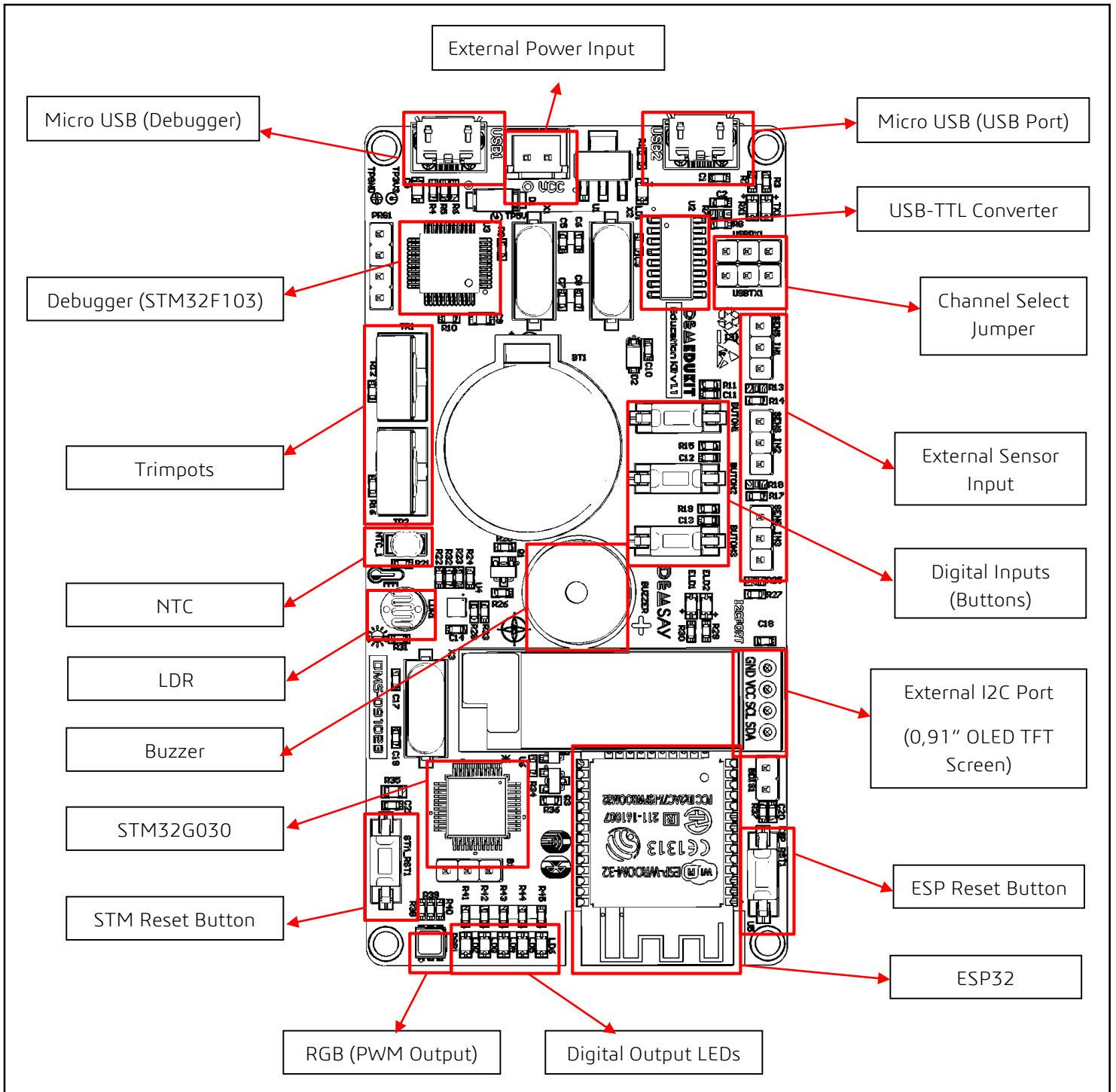

## 2.2. Bottom Layout

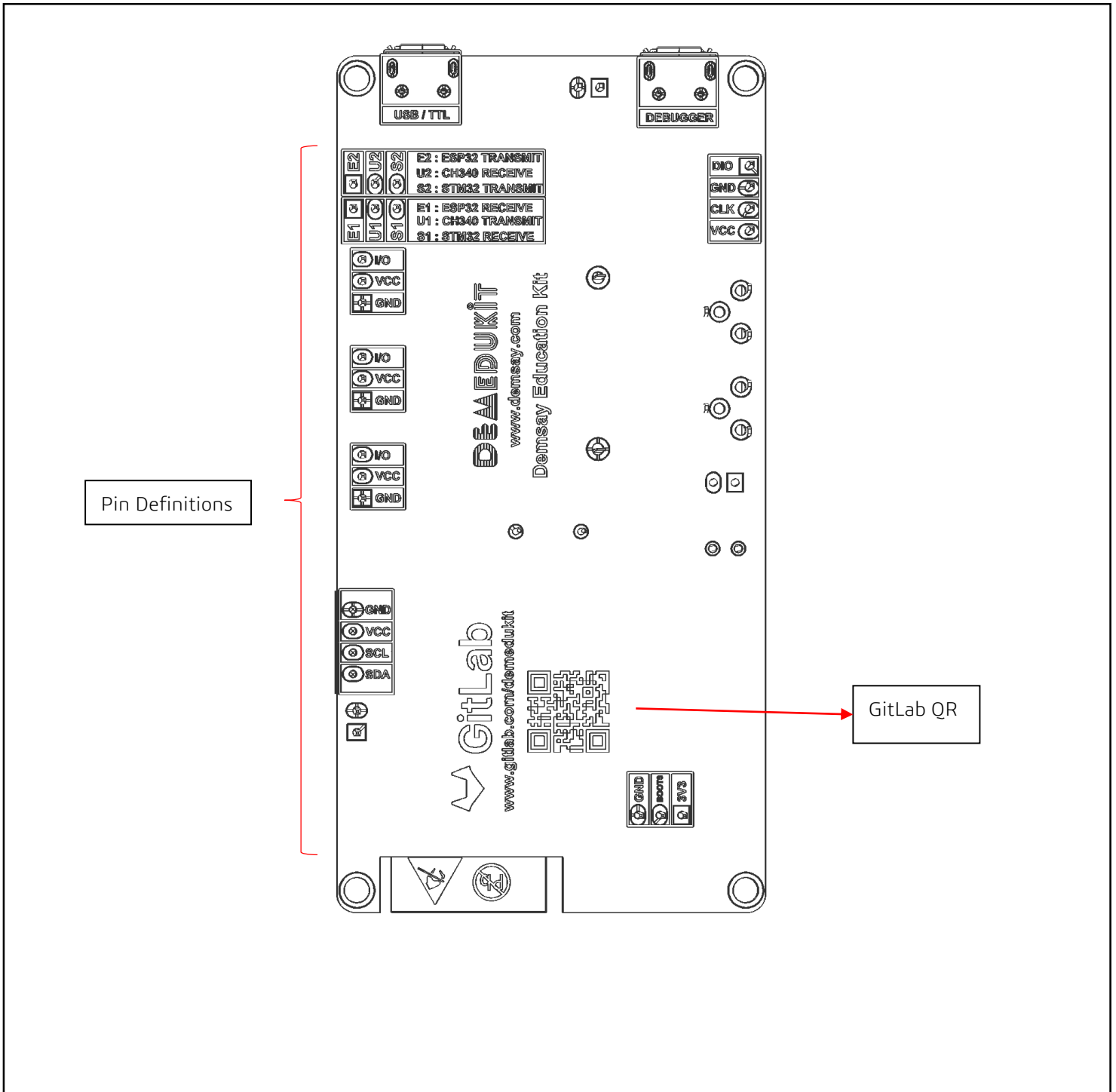

### 3. Schematic Diagram

#### 3.1. Power Diagram

The power source can be supplied externally with 5 V via 2-jst pin or micro USB.

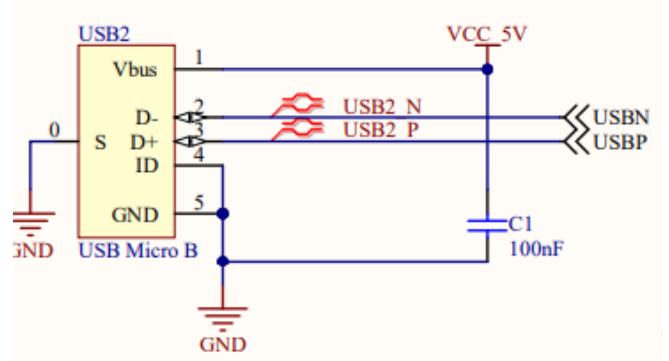
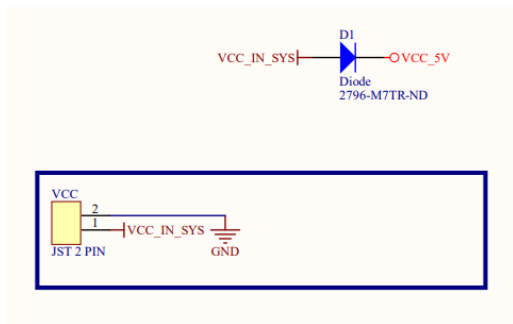
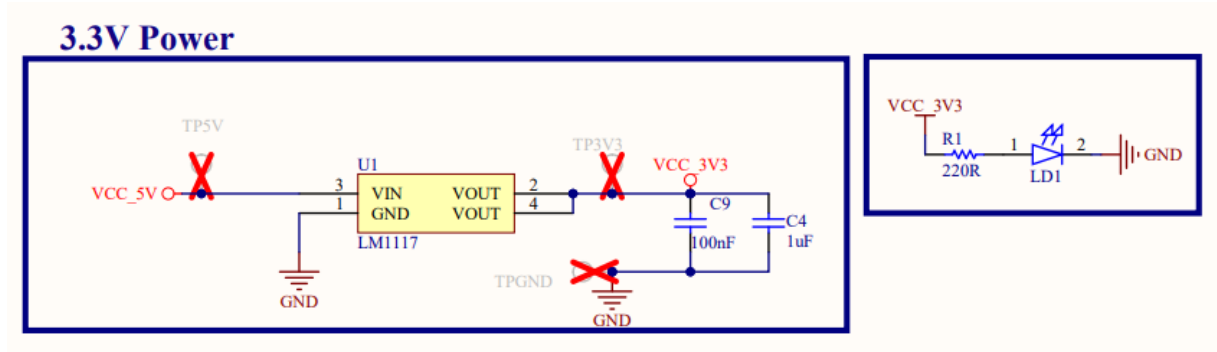

#### 3.2. STLink/V2 Debugger and Programmer

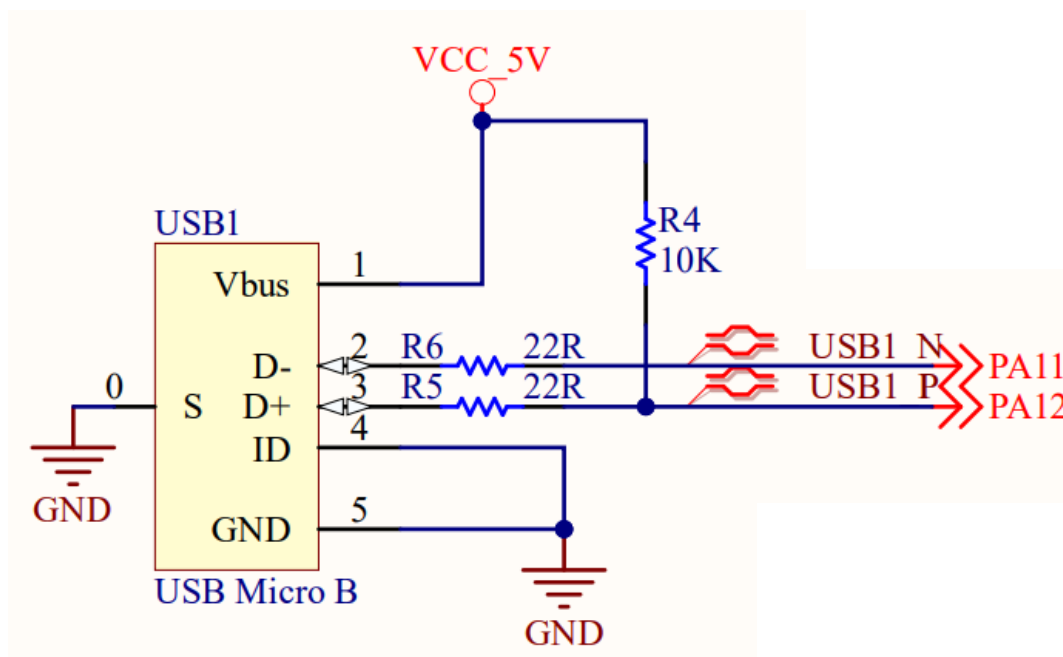

### 3.3.STM32G030 MCU Connection

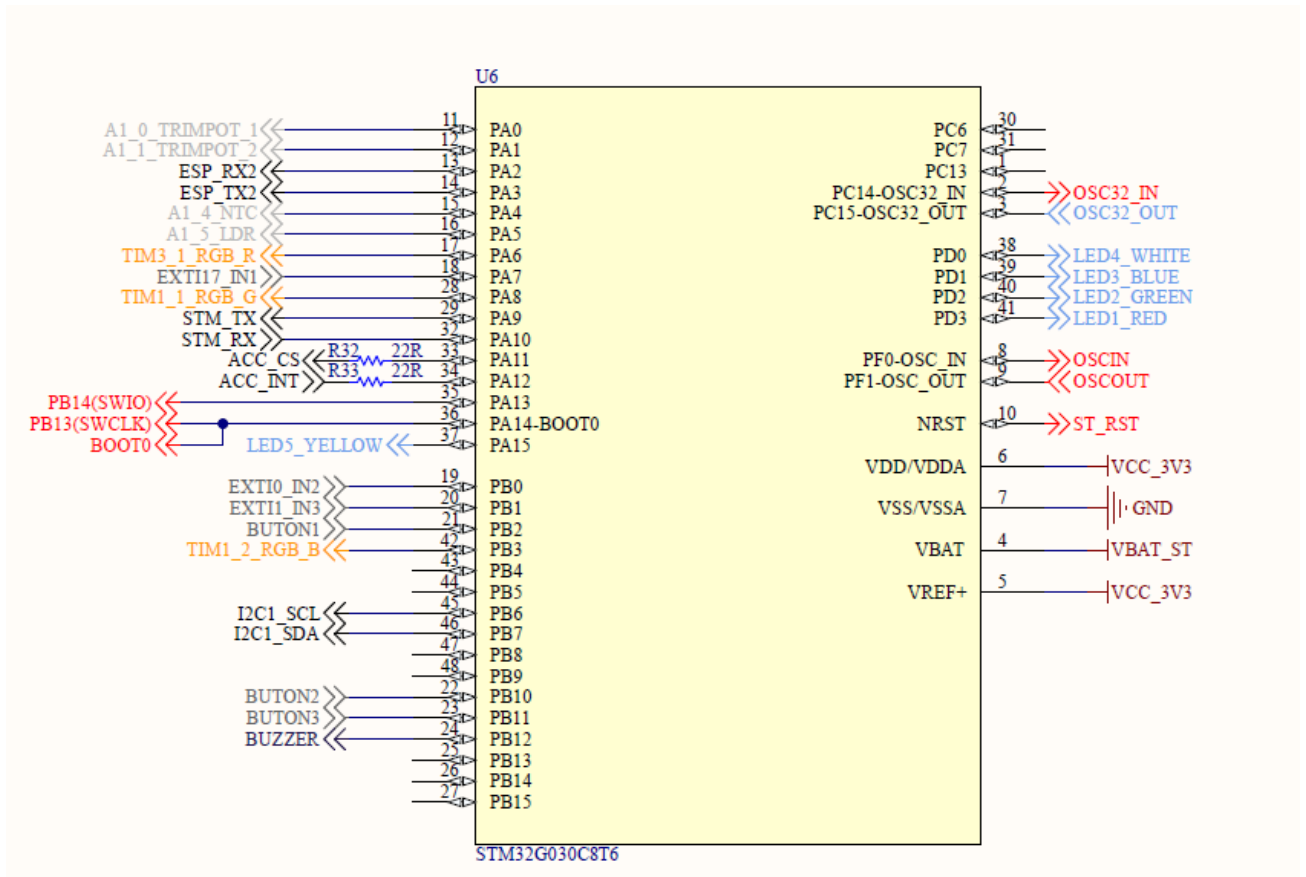

#### STMRESET

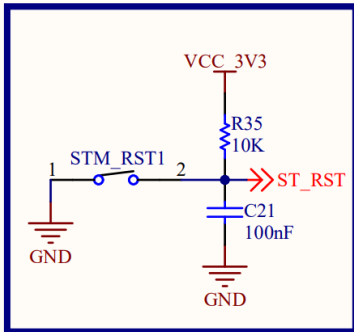

#### OSC

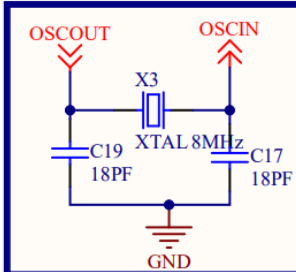

#### 32KHz OSC

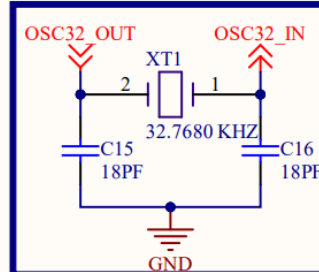

#### VBAT

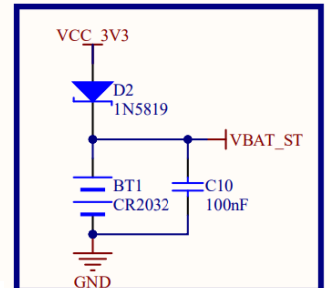

#### DE-CAPS

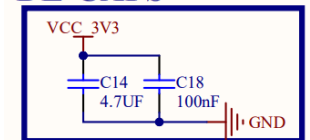



### 3.4.ESP32 – WROOM Connection

#### 3.4.1. Programming Connection

#### Micro USB FT232 Connection

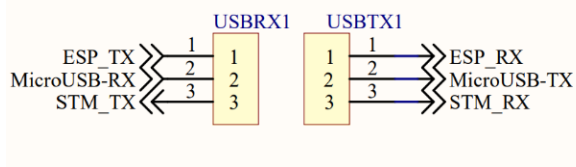
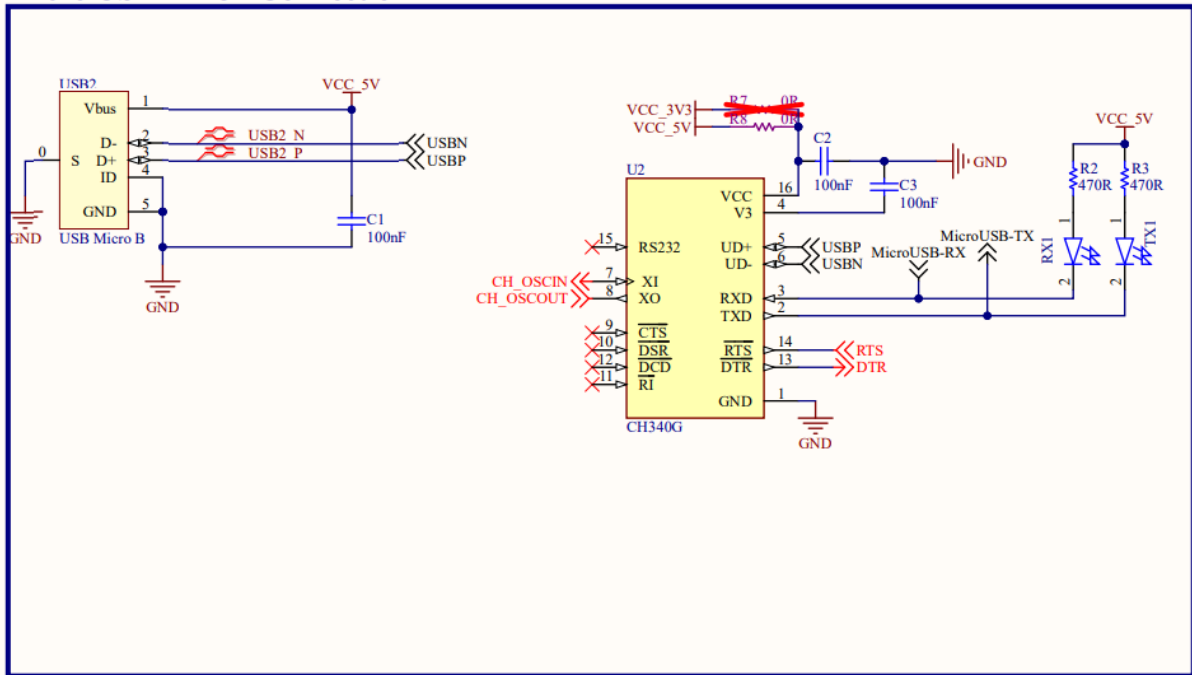

When pins **1 and 2** of the USBRX and USBTX jumpers are short-circuited, the USB converter is connected to the Software UART pins of the **ESP32**. When the jumpers are installed so that pins **2 and 3** are short-circuited, they are connected to the UART port of the **STM32**.

#### ESP32-WRoom Programming

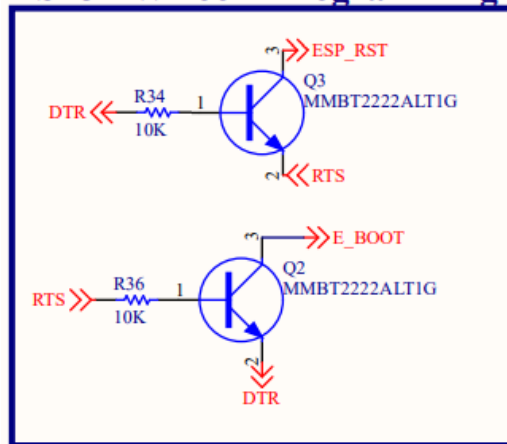

### 3.4.2. ESP32 Connection

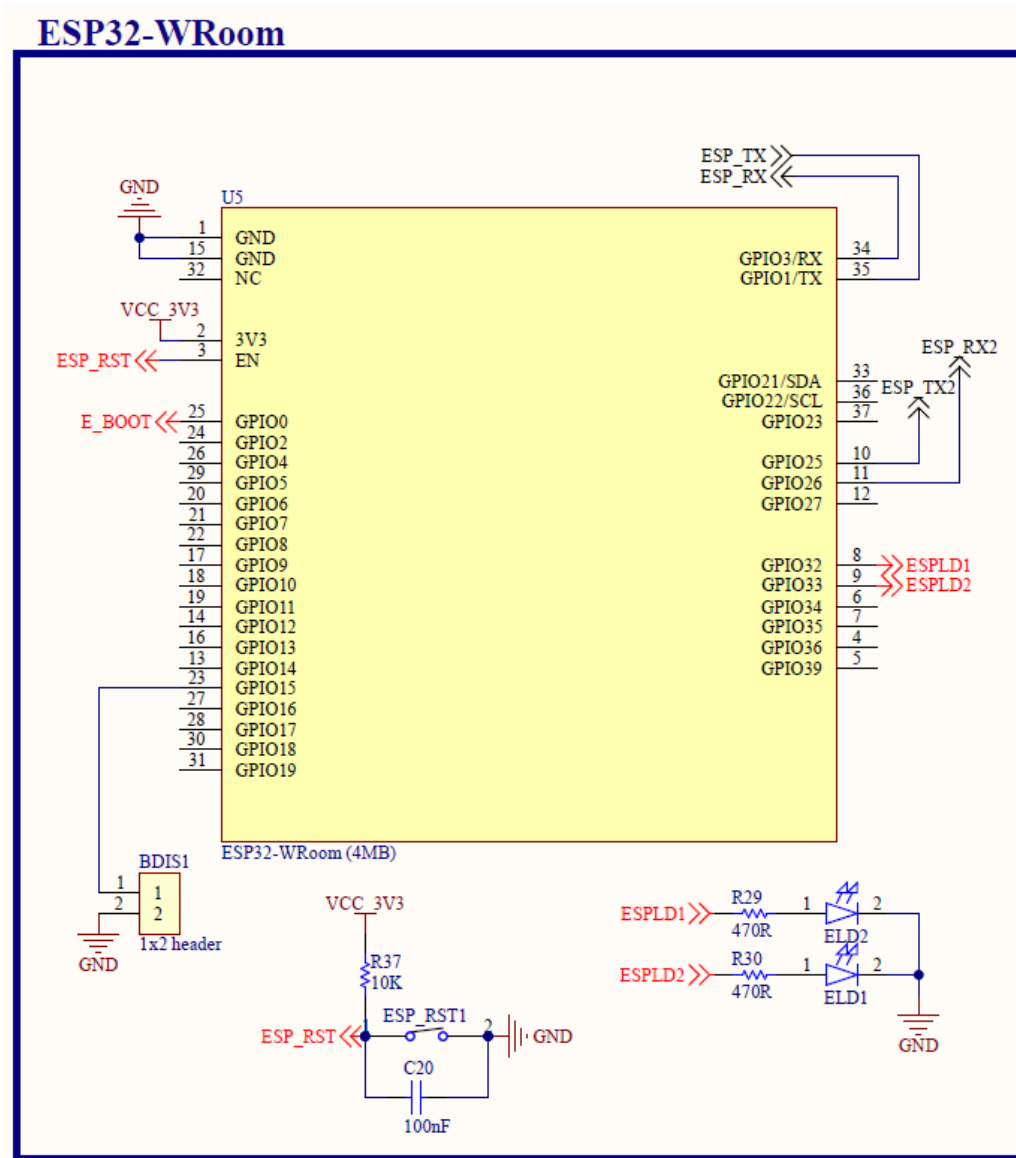

### 3.5. Input Connections

#### 3.5.1. NTC , Trimpots and LDR

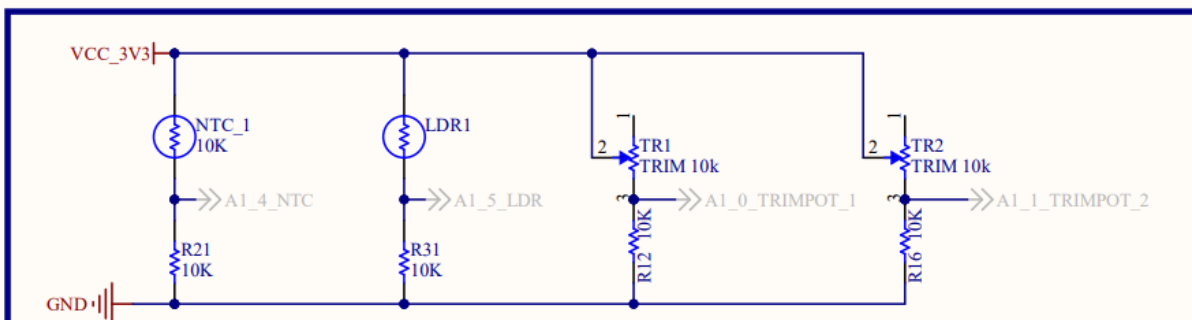

### 3.5.2. External Sensor Input

## External Sensor Connector

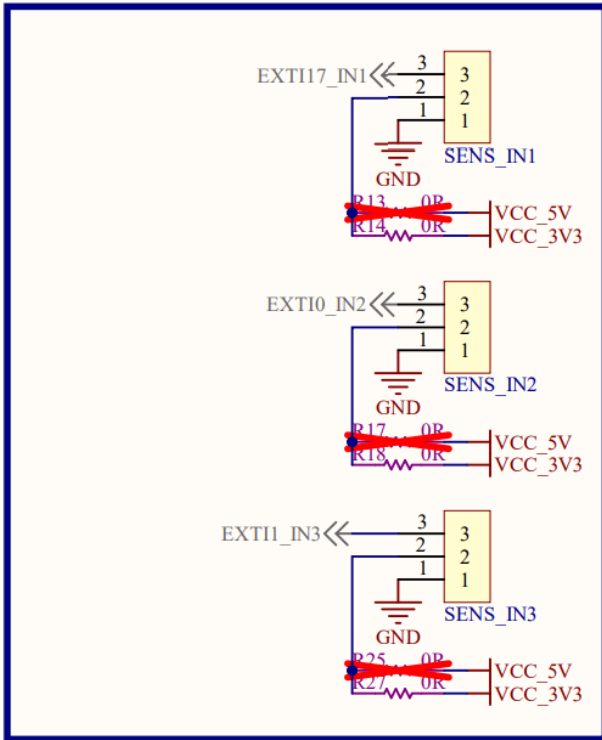

### 3.6. I2C Interface

#### 3.6.1. External I2C Port

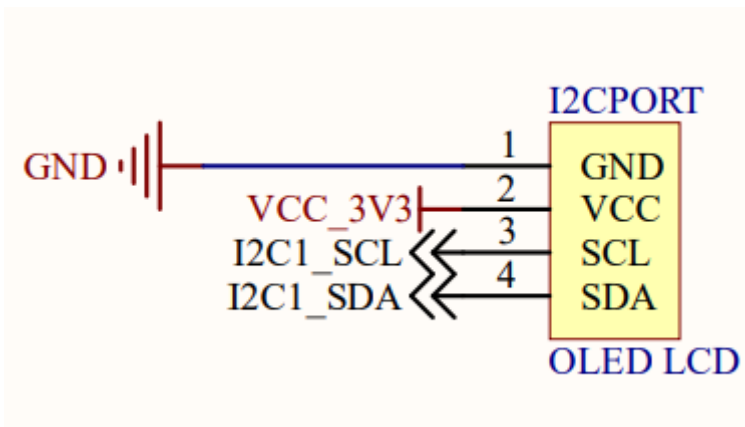

### 3.6.2. 3 Axis Accelerometer

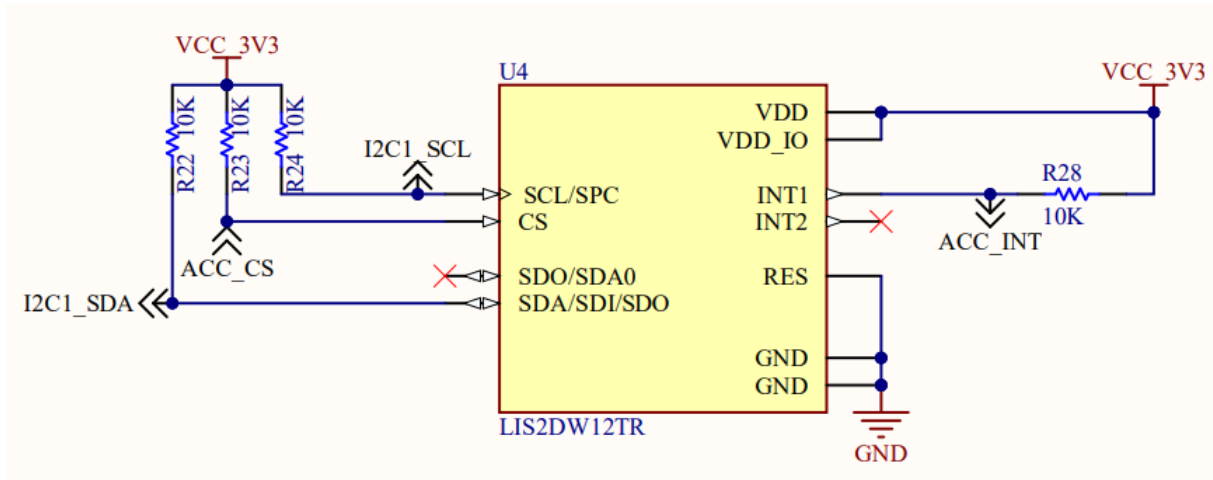

### 3.7.LED and RGB

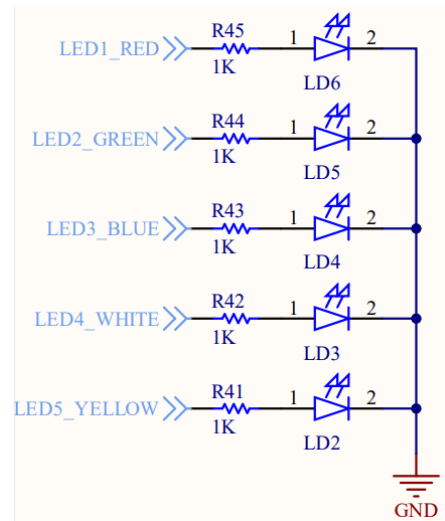
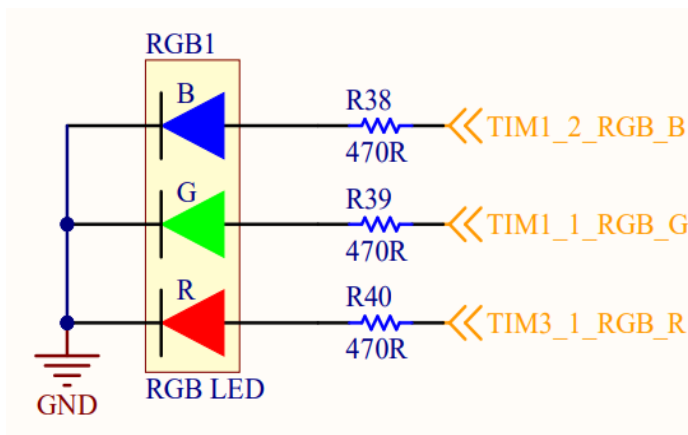

 **GitLab**  
www.gitlab.com/demedukit

